

6M SERIES

EXPECT MORE



JOHN DEERE

NOTHING RUNS LIKE A DEERE

EXPECT MORE

BUILT FOR THOSE WHO GO BEYOND THE ORDINARY.
WELCOME TO THE 6M SERIES.





CONTENTS

Introduction	2
Overview	4
6M Short Frame Tractors	8
6M Small Frame Tractors	10
6M Mid Frame Tractors	12
6M Large Frame Tractors	14
Cab	16
Engine	20
Transmissions	22
Illumination	26
Comfort and Stability	28
Hitches	30
Hydraulics and PTO	32
Axles	34
Front Loaders	36
Agricultural Management Solutions	44
FarmSight Services	48
PowerGard™	50
Editions	52
Specifications	54

THE CAN DO TRACTORS

There is a 6M for any job. Select your tractor from ten high performance models in four wheel bases.



1 | BRAND NEW CAB

Completely updated internal and external design that puts a premium on visibility with more glass than ever and a lower bonnet for ultimate front visibility.

2 | FIRST-CLASS COMFORT

Look forward to the best ride experience ever – TLS front axle suspension and mechanical cab suspension make it happen.

3 | PAYLOAD: OFF THE CHARTS

With a maximum payload of 4.7 tons and rear hitch lift capacity of up to 5.7 tons, big loads and the biggest implements are no big deal for the 6090M-6140M models.

7 | AXLES & TYRES

Take your pick from a broad portfolio of axle and tyre options including flange and rack and pinion axles.

8 | 100% JOHN DEERE

And backed by us: Engines, transmissions and full frame chassis are all designed, manufactured and tested by John Deere.

9 | HANDS-FREE STEERING

AutoTrac prevents costly overlaps and gaps – while you relax, free to focus on other tasks. Now also available on the Corner Post Display – no need for an additional display.



6M SHORT FRAME TRACTORS

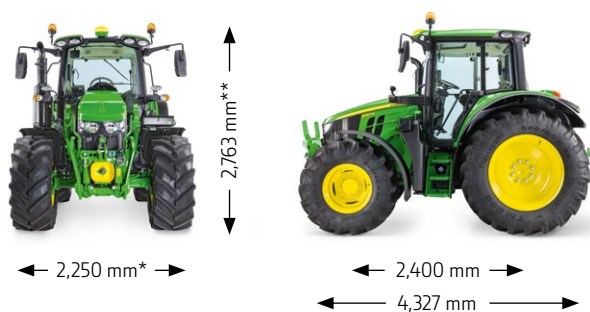

* With 320/85R24 front tyres and 420/85 R30 rear tyres
 ** Rear tyre size: 420/85 R30.
 With Cab suspension (height without Cab suspension: 2,713 mm)

5,750 KG***

6M SMALL FRAME TRACTORS

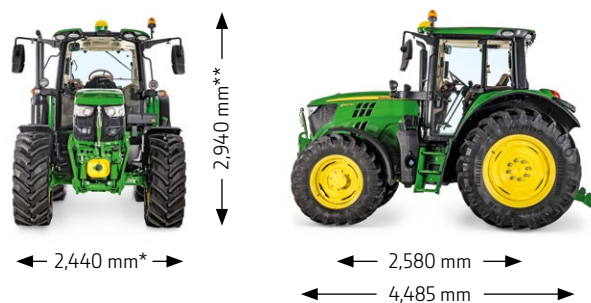

* With 540/65R28 front tyres and 600/65R38 rear tyres
 ** With Cab suspension

5,800 KG***

ENGINE PERFORMANCE

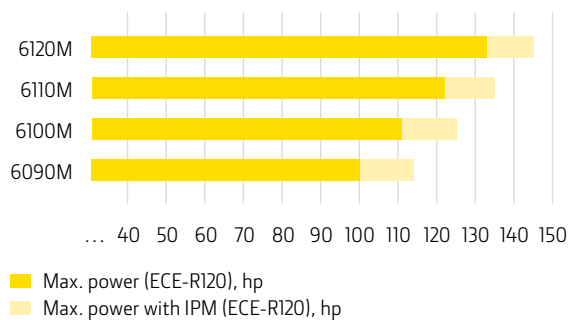

*** Shipping weight (measured with average specifications)

ENGINE PERFORMANCE

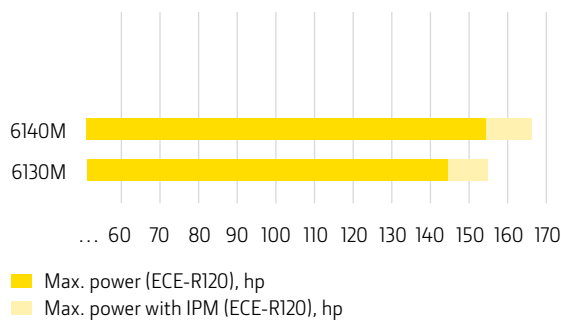

*** Shipping weight (measured with average specifications)



6M MID FRAME TRACTORS

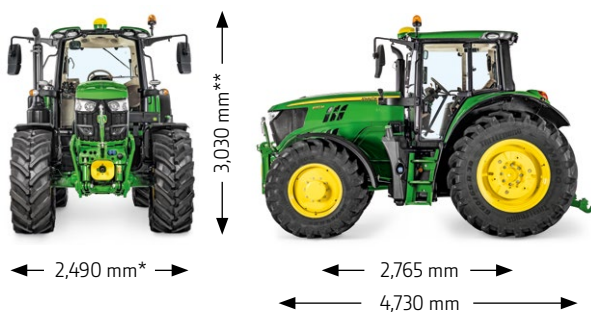

* With 540/65R28 front tyres and 650/65R38 rear tyres
 ** With Cab suspension

6145M 6,200 KG***
6155M 6,700 KG***

ENGINE PERFORMANCE

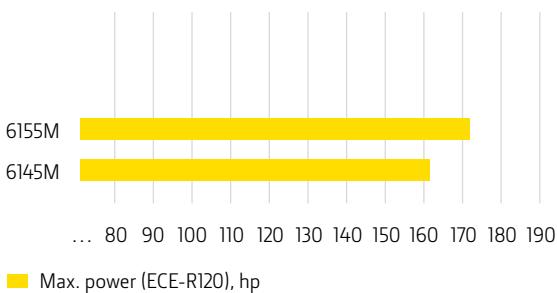

6M LARGE FRAME TRACTORS

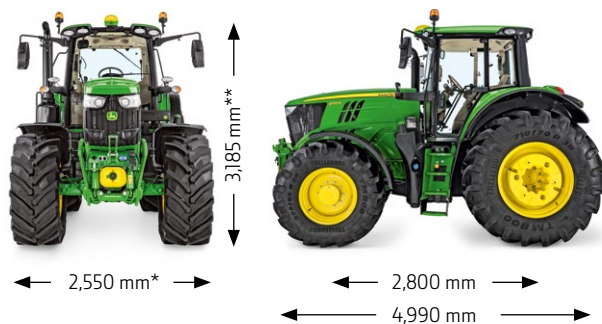

* With 600/65R28 front tyres and 710/70R38 rear tyres
 ** With Cab suspension

7,500 KG***

ENGINE PERFORMANCE

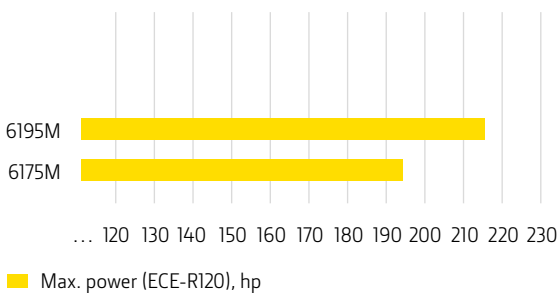



4 | ENGINE PERFORMANCE

Get all the power you need at reduced operating costs. Our 4.5 l or 6.8 l engines deliver up to 216 hp max. power and the 6090M-6140M models are also available with a 20 hp boost.

5 | TRANSMISSION CHOICES

Your high-efficiency options include PowrQuad Plus, AutoQuad Plus CommandQuad Plus and AutoPowr.

6 | STRONG HYDRAULICS

Total performance – the pressure- and-flow compensated hydraulic system with up to four selective control valves (SCV's) or three SCV's plus PowerBeyond.

10 | ENHANCED CONTROLS

Featuring eSCV as well as mSCV controls, the new right-hand console and the latest CommandARM, paired with the Corner Post Display introduce a new level of intuitive operation.

11 | CONNECTIVITY INSIDE

Available ex-factory, JDLink enables remote servicing and operator support.

WHICH 6M IS YOURS?

Finding your 6M is easy. Whether you are a livestock farmer, arable farmer, mixed farmer or run a contracting business – one of these tractors was made for you.



MAXIMUM DURABILITY

The John Deere full frame design forms the rugged backbone of all 6M Series tractors. Engine and transmission are mounted within the frame on insulating blocks that reduce stress and operating noise. It's the perfect platform for a John Deere front loader.

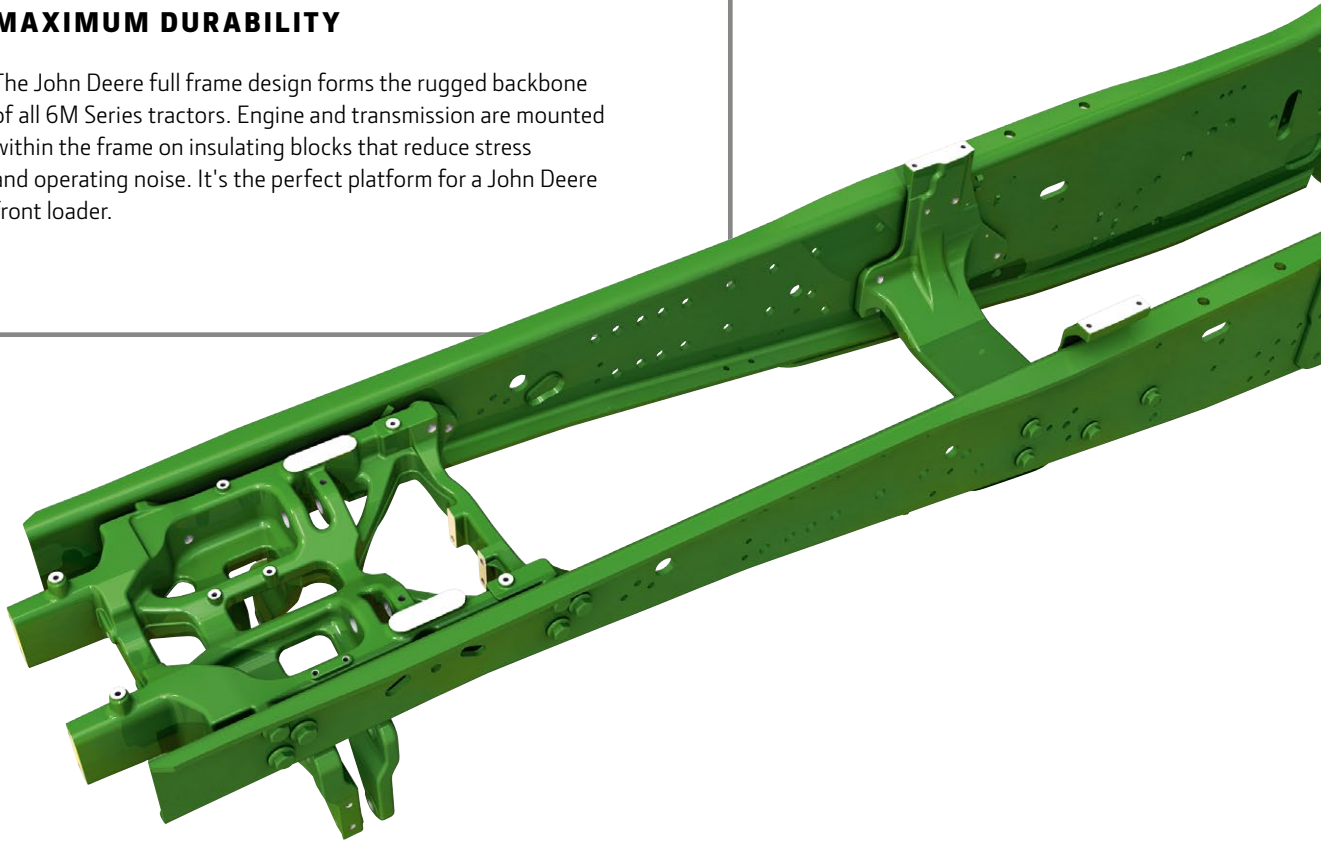

6175M, 6195M: HEAVY-DUTY PERFORMERS

When the jobs are big, numerous and tough, these are the tractors to work with. Contractors also favour them for their top on-road performance.



**6090M-6120M:
COMPACT BUILD,
AGILE PERFORMANCE**

Mowing, tedding, baling and feeding – the daily jobs of a livestock operation become quick work with these machines. Their short wheelbase also makes them perfect for front loader work.

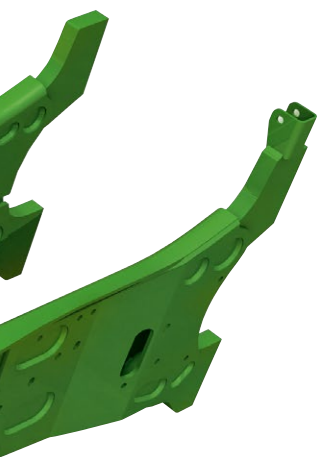

**6130M, 6140M:
THE ALL-ROUNDERS**

They've got the power to pull more in the field and handle bigger implements – they're agile enough for loader work, and strong on the road.



**6145M, 6155M:
SOLID POWER**

Tough, rugged and with plenty of power to handle the heavier side of field work like seeding and tilling for many seasons to come.

6090M-6120M

2,400 MM WHEELBASE
90 TO 120 HP PLUS 20 HP WITH IPM

Their short wheelbase and compact build make these models ideal for front loader work even in the tightest of spaces. And with a best-in-class payload of 4.7 tons, they won't break a sweat with heavy implements.



ENGINES

	6090M	6100M	6110M	6120M
Cylinders	4	4	4	4
Displacement (l)	4.5	4.5	4.5	4.5
Max. power (ECE-R120), hp (kW)	100 (73)	111 (81)	122 (90)	133 (98)
Max. power with IPM (ECE-R120), hp (kW)	114 (84)	125 (92)	135 (99)	145 (107)

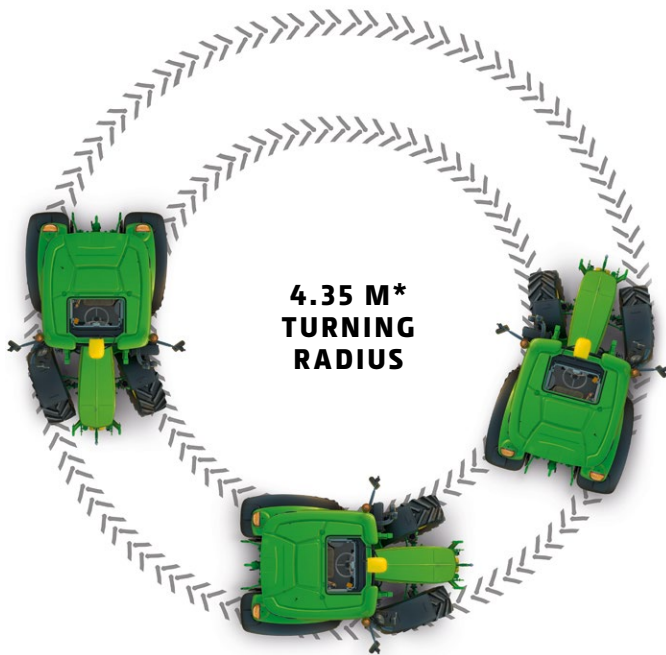

* Front Tyre Size (420/70 R24)

WORK ANYWHERE

Even with the loader mounting frames and loader connected, the 6M short frame tractors maintain a surprisingly small turning radius of 4.35 m. Perfect for front loader work in even the tightest of spaces.

HOOK UP ANYTHING

Built to handle even the heaviest of implements, the new super robust category 3N rear hitch of the 6M small frame tractors has a maximum lift capacity of up to 5,700 kg.



SEE EVERYTHING

The dropped bonnet raises front visibility to bring the action closer to you. The first spot visible in front of you is now just 6.5 m ahead.

6130M, 6140M

2,580 MM WHEELBASE
130 TO 140 HP PLUS 20 HP WITH IPM



ENGINES

	6130M	6140M
Cylinders	4	4
Displacement (l)	4.5	4.5
Max. power (ECE-R120), hp (kW)	144 (106)	155 (114)
Max. power with IPM (ECE-R120), hp (kW)	156 (115)	166 (122)

**4.5 L POWERTECH
PSS 4-CYLINDER
ENGINE**

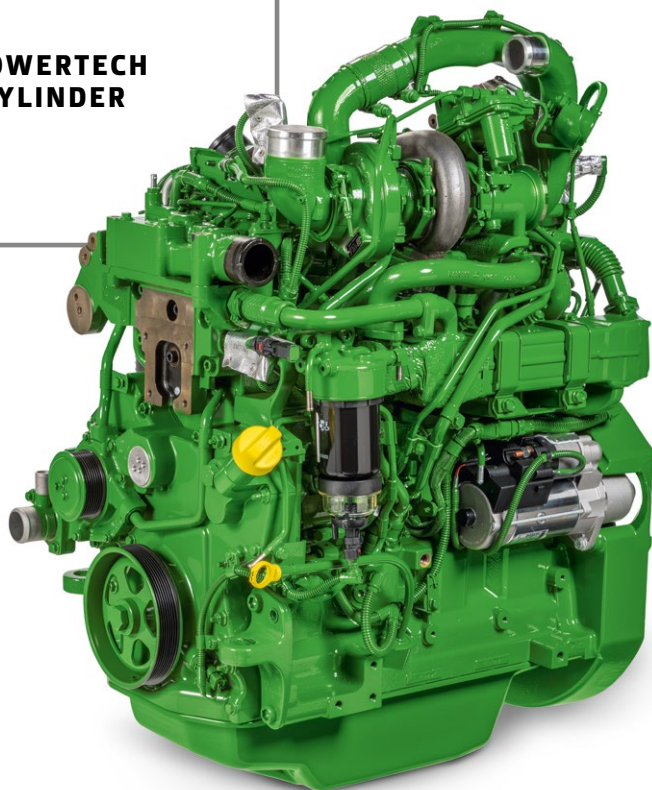

EXPECT MORE POWER

The 4.5 L PSS engine in the 6130M and 6140M delivers up to a very solid 166 hp max with Intelligent Power Management for conditions where you need a little extra.

AT HOME ON THE ROAD

Powerful engines featuring an extra 20 hp boost in a lightweight, compact format make these tractors natural transport application performers.



6145M, 6155M

2,765 MM WHEELBASE
145 TO 155 HP

With a larger wheelbase, these models deliver a very solid and comfortable ride that benefits a variety of field and transport applications.



ENGINES

	6145M	6155M
Cylinders	4	6
Displacement (l)	4.5	6.8
Max. power (ECE-R120), hp (kW)	161 (118)	172 (126)

VERSATILITY AND CAPABILITY WITHOUT COMPLEXITY



READY FOR ANYTHING

The key strengths and capabilities of our mid frames sit right in the sweet spot between agility and powerful performance.

CONVENIENT SCV CONTROL

Optionally, the 6145M and 6155M come with 3 electronic SCV's, controlled with ergonomic convenience from the compact CommandARM or the Right Hand Console. Not quite enough? You can take that up to 4 SCV's + 3 Mid SCV's if your applications require it.



RECONFIGURABLE JOYSTICK

Everything you need to control, one place to do it from: the electronic joystick enables you to reconfigure the hitch control and up to 3 SCV's in addition to gear shifting and the PowrReverser – convenient and efficient one-handed control of essential tractor functions.

6175M, 6195M

2,800 MM WHEELBASE
175 TO 195 HP

As a performance-oriented contractor or arable farmer, you will love these machines. Their extended wheelbase (2,800 mm) and large tyres let you bring all their power to the ground with maximum efficiency.



ENGINES

	6175M	6195M
Cylinders	6	6
Displacement (l)	6.8	6.8
Max. power (ECE-R120), hp (kW)	194 (143)	216 (159)



**DESIGNED
FOR COMFORT,
EQUIPPED WITH
EFFICIENCY**

**PROVEN TRACTOR EFFICIENCY
OF UP TO 90%**

How much power does a tractor actually deliver? Engine specifications in marketing materials are often misleading. What matters is not the engine power or the decal on the bonnet, it's the efficiency with which the available power is transmitted to the ground or to the PTO – in a 6M that is an impressive 90%.

WORK SMARTER

The new corner post display and compact CommandARM with electronic SCV: tools to enhance your comfort and keep your productivity high.





In the 6M's productivity cab everything is optimised for making the most of your time there.

THE SEE MORE, DO MORE CAB

When we designed this tractor cab, our purpose was simple: to help you do more, with more ease. Your 6M workspace is all about intuitive and straightforward tractor operation. Guided by best-practice ergonomic principles, the design of the 6M's right-hand console and the new compact CommandARM is perfectly aligned with the new Corner Post Display in A-post – it's a smoothly productive operator experience which is enclosed by more glass all around for a wide-open, unencumbered view.



PANORAMA ROOF

When you've got some weight on your loader, you need to be in full visual control of the situation. The newly designed panorama roof enables you to be more accurate and quicker whatever the front loader task is.

MORE CONTROLS, YOUR CHOICE

You're going to spend many hours in your 6M. Thankfully, we just made that a whole lot more comfortable and convenient.

Everything about the controls in a 6M is about one thing – making the complex operations and manoeuvres of your day in the tractor as easy as possible: The combination of the Corner Post Display, the new right hand console and the compact CommandARM provides a completely intuitive interface to your 6M, with effortless fingertip control and easy monitoring of all tractor functions.

1 | CORNER POST DISPLAY

Featuring user-friendly graphics and precise digital gauges, the dashboard gives you a well-organised overview of all major systems.

2 | NEAT AND TIDY STORAGE

If you like your cab uncluttered but still have items you need to bring along, this is where you can keep them conveniently accessible. Alternatively, there's a fridge that fits the space.

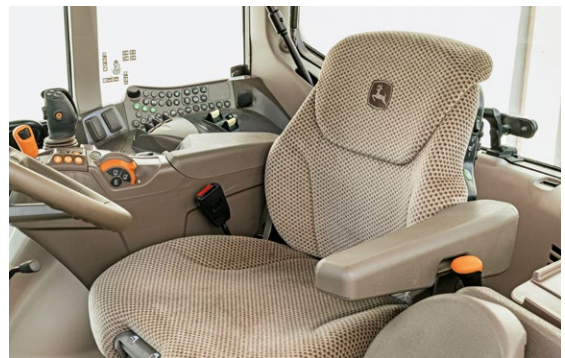

3 | SIT WELL

No matter how long your day in the cab – this mechanical seat has the adjustments and suspension characteristics to make sure you're comfortable and protected.



The intuitive interface to your 6M: The Corner Post Display in A-post and the new compact CommandARM.



6 | NEW COMPACT COMMANDARM

Better controls give you more control: Operate all transmission functions at the highest level of comfort, control AutoTrac, set engine speed with precision and control the rear hitch.



7 | ELECTRONIC JOYSTICK

Ergonomically positioned on the new compact CommandARM or on the Armrest, the electronic joystick is great for loader applications or can also be reconfigured for operating three eSCV's, rear hitch or one ISOBUS AUX functionality.

CORNER POST DISPLAY

ONE GLANCE, ALL THE INFORMATION



Autotrac – now conveniently integrated right here



Turn lights on/off



Hitch menu – Load depth, upper limit, drop rate



Transmission menu – Eco engine speed, reverser ratio



Hydraulics menu – Hydraulic flow control



Drop PTO on – Drop to target – PTO engaged



Performance monitor – Measure performance, hectare count

iTEC

iTEC Basic menu – iTEC on/off, and choose functionality



Maintenance menu – Check/control service interval + diagnostics



INSTANT STATUS

Located on A-post, in direct line of sight, the Corner Post Display shows important messages and warnings about essential tractor functions. It's conveniently operated by the combination of a selection wheel and quick access keys on the right-hand console.



Intuitive, streamlined tractor function control at its finest: The Corner Post Display in A-post and the right-hand console.



4 | NEW RIGHT HAND CONSOLE

You've got all the basics covered with this one – it's ergonomically designed, with all of the most essential controls within easy reach for you.



5 | UNIVERSAL DISPLAYS

The Gen4 4240 and the 4640 displays are your best choice if you are looking for an easy to use and fully ISOBUS AEF certified display with tablet like swiping that is also AutoTrac and section control capable. Add JDLink telematics module and a JDLink Connect subscription and you also get wireless data exchange with the John Deere Operations Center.

POWER WITHOUT LIMITS

Get all the power you need with less fuel and lower emissions from our two 4.5 l 4 cyl. or our 6.8 l 6 cyl. engines. The 6 cyl. engine features extended drain intervals of up to 750 hours.*

SOLID POWER

Compact goes beyond. Whatever the job, the 4.5 L EWL engine will deliver more than enough power thanks to 40% torque reserve and Intelligent Power Management.



6120M

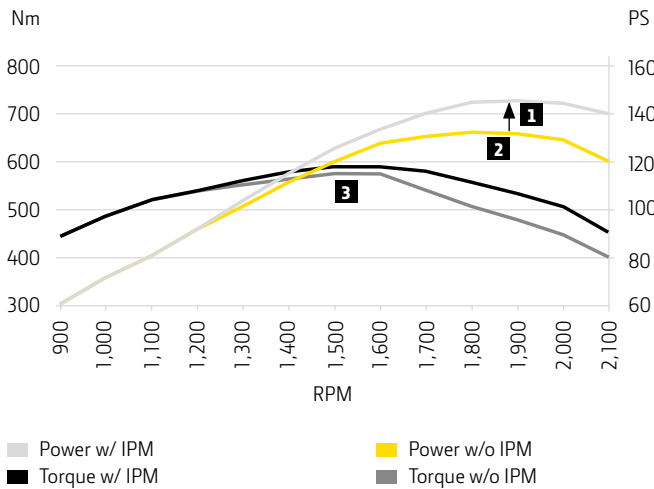

Intelligent Power Management (1) provides up to 20 additional hp for transport and PTO applications. Max. power (2) and max. torque (3) are achieved at 1,900 and 1,500 rpm respectively to ensure optimum response with low fuel consumption levels.

* for selected equipment with John Deere Final Tier 4 engines when using Plus-50 II John Deere filters.





**LONG 750 H OIL
CHANGE INTERVAL***

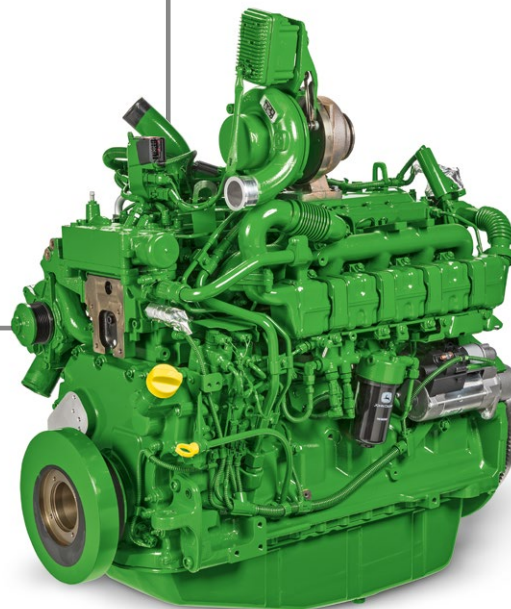

PROVEN TECHNOLOGY

The higher power output of our 6-cyl. engines comes from refined High Pressure Common Rail technology with injection pressure of up to 2,500 bar. The PVS engine in the 6155M, 6175M, and 6195M has a Variable Geometry Turbocharger that boosts performance and efficiency across the torque curve.



PROVEN: EFFICIENT TRANSMISSIONS

POWRQUAD PLUS, AUTOQUAD PLUS AND COMMANDQUAD PLUS

Our proven transmission portfolio combines superior ease of operation and convenience with outstanding efficiency to complement the power and torque of your 6M. For the 6090M-6155M models a creeper option with speeds as low as 72 m/h at 1,000 rpm is available.



POWRQUAD PLUS

Two versions are available: 20/20 and 24/24. All provide rapid shifting including speed matching for smooth shifting between ranges. They are operated by a single range lever with declutch function and push-button gear selection. SoftShift technology keeps the changes smooth, even under load.



AUTOQUAD PLUS

All the benefits of PowrQuad Plus with the added convenience of automatic gear shifting. 20/20 and 24/24 versions are available. The EcoShift option combines high transport speed (40 km/h) and low engine rpm between 1,580 and 1,680 to reduce fuel consumption and emissions by up to 23%.



COMMANDQUAD PLUS

Looking for that extra level of operational ease? Say hello to a lot less clutching and experience less tiresome, more productive days in the cab. You'll love the enhanced automatic capabilities of CommandQuad Plus.

FULL AUTO MODE

Seamless driving that combines automatic shifting with fuel savings at a high level of convenience.

STOP-AND-GO EASE

The AutoClutch function lets you stop the tractor without pressing the clutch – it makes a huge difference if you do a lot of stop-and-go work.

EFFICIENT MULTI-RANGE SHIFTING

Fully robotised gear and range shifting: no clutching required. Using the double-bump feature, you can shift up one range with a quick double bump (C1 to D1 for example).

ECOSHIFT ALSO AVAILABLE

With a transport speed of 40 km/h, this version fully automatically operates at engine speeds of only 1,670 rpm.

- 1 | Speed wheel
- 2 | Shift lever
- 3 | Automatic mode
- 4 | Manual mode
- 5 | Range selection



AUTOPOWER

INFINITE SPEED ADJUSTMENT

AutoPowr is a hydro-mechanical transmission that delivers stepless and continuous power at speeds between 50 m/h and 40 km/h. AutoPowr maintains the selected speed by automatically responding to changing load conditions. Once running at maximum road speed, engine rpm automatically drops to the minimum level required to maintain that speed – reducing noise and saving fuel. 40 km/h is maintained at 1,470 rpm.



**FINALLY, ULTIMATE
CONVENIENCE ALSO
MEANS SUPERIOR
EFFICIENCY**

- Mechanical power
- Hydrostatic power

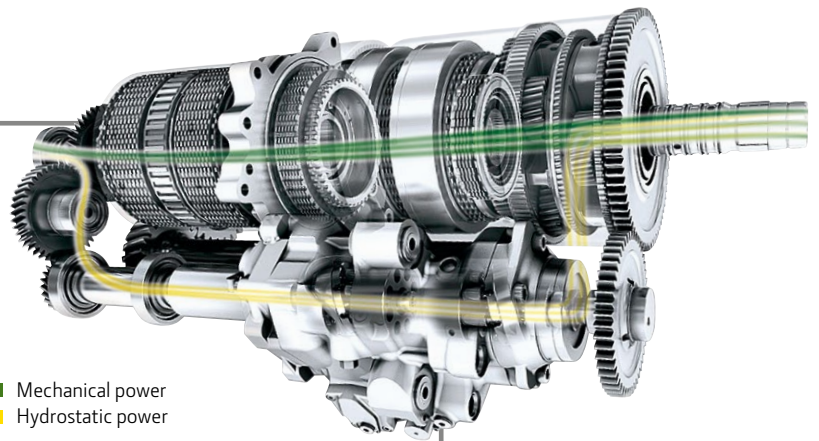

AutoPowr on the right-hand console



AutoPowr on the compact CommandARM



Stepless and variable speed setting allows you precise and comfortable adjustment for each application.

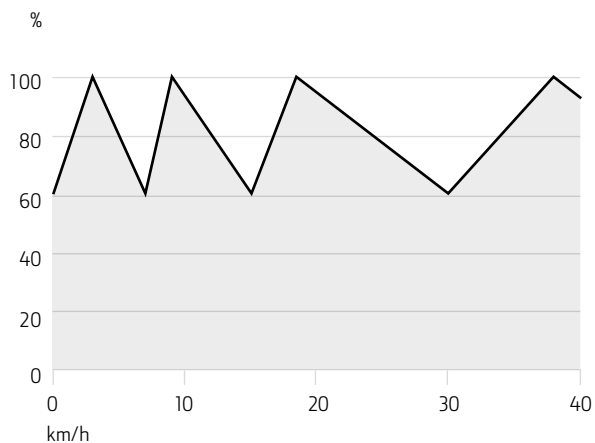

MAXIMUM EFFICIENCY

AutoPowr delivers 100% mechanical power at the following working speeds: 3 km/h (heavy draft), 9 km/h (light draft), 18.5 km/h (heavy transport) and 38 km/h (light transport). This results in superb transmission efficiency, close to that of mechanical transmissions. In fact, AutoPowr always converts more than 60% of the available power mechanically.

- 1 | Set-speed adjusting wheel
- 2 | Speed band two
- 3 | Speed band one





Work lights are cleverly integrated into the front, rear and sides of the roofline to prevent damage from low branches.

LIGHT UP THE NIGHT

Stay productive 24/7 with the bright 360° visibility from lighting packages with up to 12 cab lights.



Get ready for a brand new kind of night: Our factory-installed lighting packages deliver a wide, bright and concentrated field of light all around your 6M. For even more demanding lighting requirements you'll want to opt for our LED lighting packages which consume less power, provide an even brighter, daylight-quality light and last longer.

SELECT LIGHT PACKAGE

- 1 | Four front grille mounted halogen lights (6090M-6120M)
Six front grille mounted halogen lights (6130M-6195M)
- 2 | Eight cab roof mounted halogen lights
- 3 | Two belt line mounted turn lights
- 4 | Two fender mounted brake and turn lights

OPTIONAL

- 5 | Footstep lights on both sides
- 6 | Two belt line work lights (HB3 or LED)
- 7 | Two belt line road lights (H4)
- 8 | Single or dual beacon lights

SELECT+ LIGHT PACKAGE

- 1 | Four front grille mounted halogen lights (6090M-6120M)
Six front grille mounted halogen lights (6130M-6195M)
- 2 | Ten cab roof mounted halogen lights
- 3 | Two belt line mounted turn lights
- 4 | Two fender mounted brake and turn lights
- 5 | Footstep lights on both sides

OPTIONAL

- 6 | Two belt line work lights (HB3 or LED)
- 7 | Two belt line road lights (H4)
- 8 | Single or dual beacon lights

PREMIUM LIGHT PACKAGE

- 1 | Four front grille mounted LED lights (6090M-6120M)
Six front grille mounted LED lights (6130M-6195M)
- 2 | Ten cab roof mounted LED lights
- 3 | Two belt line mounted turn lights
- 4 | Two fender mounted brake and turn lights
- 5 | Footstep lights on both sides

OPTIONAL

- 6 | Two belt line work lights (HB3 or LED)
- 7 | Two belt line road lights (H4)
- 8 | Single or dual beacon lights





The John Deere full frame design provides a robust platform that effectively absorbs and resists loads and shocks – you're guaranteed a smooth and comfortable ride when you're on the road.



MECHANICAL CAB SUSPENSION

Say goodbye to vibrations and drive all day with relaxed focus. Our maintenance-free mechanical cab suspension pays for itself with increased operator productivity and best in class comfort.



COMFORT THAT KEEPS YOU SHARP

A long day in the cab is hard work. Shocks and vibration cause fatigue. Proper suspension alleviates these effects and helps keep operators alert.

The John Deere full frame design is a solid platform that absorbs, and resists loads and shocks from the wheels, heavy implements and front loaders. To further minimise the fatigue and stress caused by unpleasant vibrations, 6M tractors can be specified with optional mechanical cab suspension. The standard front axle delivers superior on-road handling – Triple Link Suspension (TLS) is optionally available.

TRIPLE LINK SUSPENSION

TLS – one short acronym with lots of benefits behind it:

- 7% more power to the ground than with a rigid axle
- A long draft member for better draft performance
- Hitch sensing system synchronisation to compensate power hop effects under heavy pull
- Self-levelling with 100 mm suspension travel
- Automatic axle sensitivity and suspension rate adjustment
- Optional brake discs in front axle hubs for more braking capacity

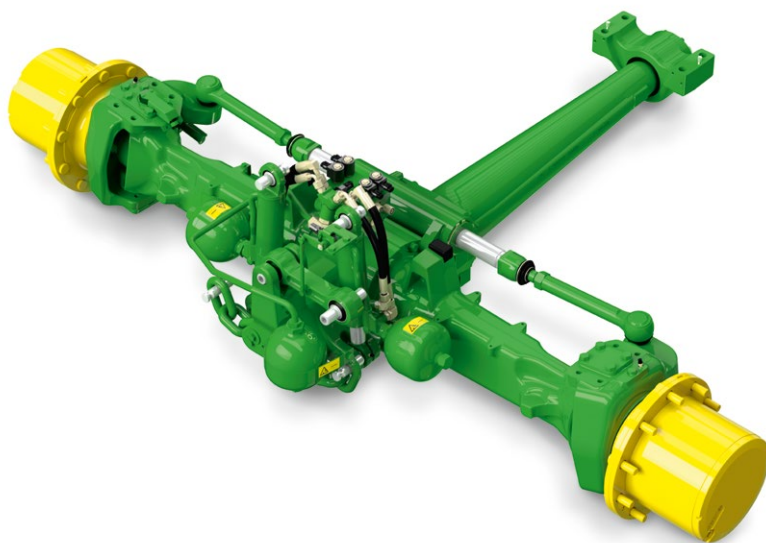

GET HITCHED TO PRODUCTIVITY

Access all your pulling power across a wide variety of implements and applications with the many hitch, PTO and drawbar options of the 6M series.



POWERFUL HITCH OPTIONS

To easily handle heavy implements, 6M tractors offer three different rear hitch options. A category 2/3N with lift capacity of up to 6,400 kg and a category 3N/3 for lifts of up to 9,050 kg.

REAR PTO CHOICES

An independent 3-speed manually shifted rear PTO is standard on all 6M tractors – options include: 540/540E/1,000.



Automatic and mechanical wagon hitch with 38 mm ball-pin



Piton fix hitch



Ball-type hitch



Forced Steering System

AUTOMATIC WAGON HITCH

Makes attaching implements much more convenient compared to manual wagon hitches.

BALL-TYPE AND PITON FIX HITCHES

Fulfilling all customer requirements, these hitches provide optimum traction and driving dynamics for tractor/trailer combinations.

FORCED STEERING SYSTEM

For even higher versatility our hitches can also be equipped with a forced steering system to operate large trailers with steering axles (attachment only).



BIG FRONT HITCH LIFT

There's more: Get up to 4,400 kg maximum lift capacity with our optional, fully integrated front hitch, or even order your 6M with a front PTO.

SMART MUSCLE ON TAP

On par with its premium segment sibling, the 6M features the same rear hitch geometry as the 6R Series tractors.

EFFICIENT FLOW CONTROL

Easily controlled via the Corner Post Display, the 6M's Pressure and Flow Compensated system (PFC) will produce a powerful flow of up to 155 l/min. The smart part comes in when flow is not needed: The system automatically enters a "no flow" standby mode – improving fuel efficiency, implement performance and steering response. For operations with less demanding tasks, a cost effective, more basic Pressure Compensated system (PC) with 80 l/min is also available.

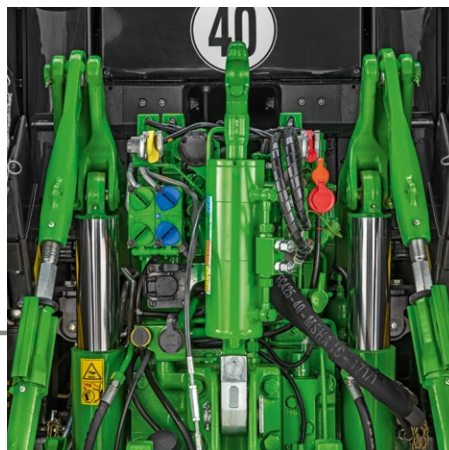

EASY SCV ACCESS

Conveniently located between the rear hitch rails, the SCV stacks groups together, up to 4 SCV's or 3 SCV's plus Power Beyond, and the Pressure-Free Return circuit valve, with hydraulic flow easily adjusted from the Corner Post Display.





Adjustable Load Sensing: up to +24 bars for efficiently running implements that require high oil flow.

HYDRAULIC PUMPS

With pressure and flow compensated (PFC) systems, the hydraulic pumps on the larger 6M models deliver up to 155 l/min of flow, while the pressure compensated (PC) systems on the 6090M-6140M tractors go up to 80 l/min.

	6090M-6140M	6145M-6155M	6175M-6195M
PC 80 l/min	■	-	-
PFC 114 l/min	□	■	■
PFC 155 l/min	-	-	□

■ base □ optional - not available

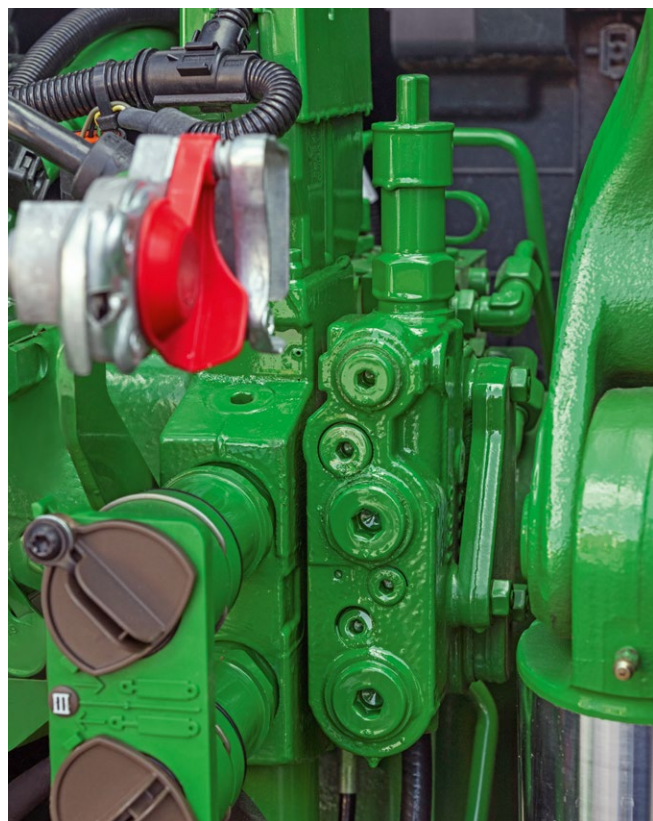

ALL TERRAIN, EVERY APPLICATION

Depending on the tread adjustment requirements of the jobs you mostly work with your tractor, you can choose between flange or rack and pinion axles on your 6M.



FLANGE AXLES

Fixed or Adjustable wheels:
Available for all 6M models, these rear axle solutions give you various width settings. If that works for what you do, these axles are a great alternative to the more versatile rack and pinion axles.

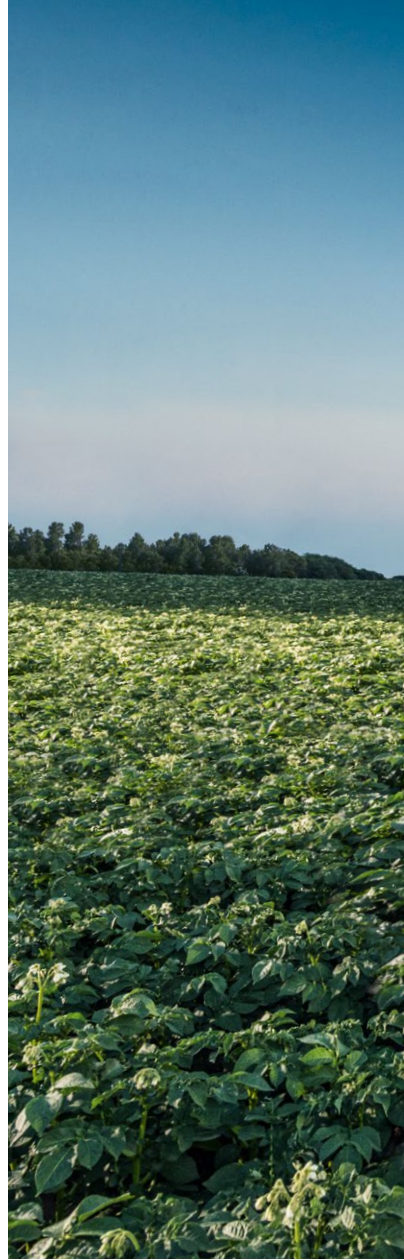

RACK AND PINION AXLES

Cast wheels and the rack-and-pinion design have a couple of advantages: The heavier design provides additional weight, while making tread adjustments quick and easy. If many of your jobs require high clearances, you'll be well served with our two-position steel wheels with rack-and-pinion axles.



79 mm x 2,286 mm
79 mm Shaft – Short version

Available for:
6090M, 6100M, 6110M,
6120M, 6130M, 6140M



79 mm x 2,550 mm
79 mm Shaft

Available for:
6090M, 6100M, 6110M,
6120M, 6130M, 6140M



86 mm x 2,438 mm
86 mm Shaft

Available for:
6090M, 6100M, 6110M,
6120M, 6130M, 6140M, 6145M



92 mm x 2,550 mm
92 mm Shaft

6155M, 6175M, 6195M

GOT FRONT LOADER WORK?

In designing the 6M we paid particular attention to address front loader work requirements: manoeuvring to the load, seeing what you're doing and delivering the power you need.

The combination of a short 2,400 mm wheelbase, reduced overall length and a nimble turning radius of 4.35 m is guaranteed to get your 6M exactly where you need it to be.

On certain terrains, front loader work can be a tricky balancing act. Not in a 6M. Its super strong integrated casting frame and a low centre of gravity give you the rock-solid foundation from which to master even the most challenging front loader jobs.

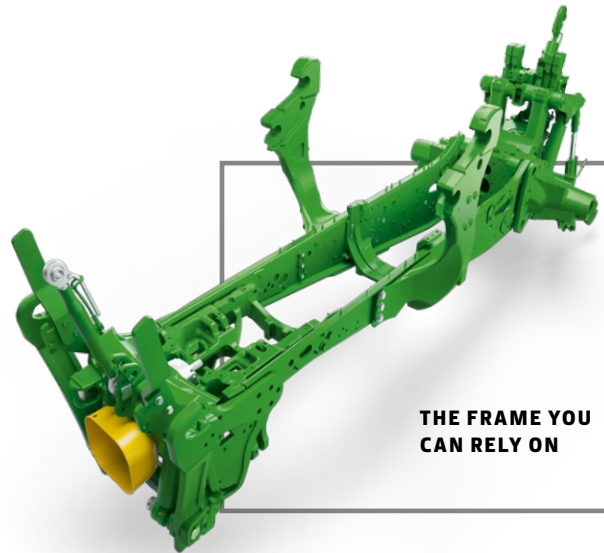

THE FRAME YOU CAN RELY ON



FULLER VISION

Working in a 6M cab feels like the blinkers have been taken off: the panorama roof, the panoramic windscreen and the low bonnet open up your field of vision like never before.



BORN TO LIFT

The 6M gives you a lot of power to work with. Its advanced Pressure and Flow Compensated (PFC) hydraulic system can produce a flow of up to 114 l/min – that translates into more power and faster cycle times than you'd expect in this class of tractor.

6M owners swear by the simple ease of clutchless forward/reverse using the left-hand reverser or the new reverser on the joystick.



- 1 | Gear Shift Switch
- 2 | 3rd function, 4th function – activation of diverter (2+1F)
- 3 | Loader Suspension ON/OFF
- 4 | Reverser



MECHANICAL JOYSTICK WITH REVERSER

The mechanical Joystick provides convenient control. Additional joystick functions include GSS, diverter valves, loader suspension and reverser.



ELECTRONIC JOYSTICK WITH REVERSER

Easily the most comfortable way to operate a front loader: the new reverser on the joystick lets you change the tractor's direction with the push of a button and shift gears on buttons 5 or 7.

M SERIES LOADERS

LIGHT AND VERSATILE

This is the readily available and affordable all-you-need solution for all standard applications – straight from the factory or as a retrofit.

Light weight with fast cycle times, M Series loaders feature mechanical self-levelling (MSL) and offer two independent functions plus a diverter for the 3rd function. They have the same mounting frame as our R Series loaders for full fleet compatibility.



SEE IT ALL

The design of the M Series is optimised for exceptional visibility when you connect your implements and of course during loader operation.

TIME SAVING

Connect and disconnect the loader in less than 5 minutes and change implements with just one easily accessible lever.

EASY MAINTENANCE

All bushings can be greased, the relevant ones can be replaced, and hydraulic hoses are protected inside the boom, with easy access to all main hydraulic parts if ever needed.

A SMOOTHER RIDE

The optional suspension provides a smoother ride for load, tractor and operator.



**AFFORDABLE, FASTCYCLE
PRODUCTIVITY FOR
ALL YOUR JOBS**

TRACTOR/LOADER COMPATIBILITY

Three M Loader models are available for the 6M tractors.

	603M	623M	643M
6090M, 6100M, 6110M, 6120M	■	■	-
6130M, 6140M	-	■	■
6145M, 6155M	-	-	■

R SERIES LOADERS

RAISE YOUR GAME

Designed for unrestrained productivity and peerless ease of use, these loaders withstand the toughest conditions.

Easy to mount, quick to take off – it's the key to higher productivity. John Deere R Series front loaders have our automatic latch designs, making the installation of loader and implements as easy as click & go. Different self-levelling options are available. The John Deere levelling link design makes more power available for lifting and never gets in the way of the operator's view.



UNDERSLUNG LEVELLING LINK

The geometry of our front loader linkage has several advantages. The underslung levelling link does not impair your view, conveys more power and provides easier access for servicing.



CLICK AND GO

Mounting our front loaders could not be quicker or more convenient thanks to the self-correcting floating system of the built-in automatic mast latch. Separation is just as easy.



AUTOMATIC IMPLEMENT LATCH

The implement is self-guided by centre guides and is automatically latched as soon as it reaches the carrier frame.



**MORE LIFT
CAPACITY AND
MORE PRACTICAL
CONVENIENCE TO
GET MORE DONE**



TRACTOR/LOADER COMPATIBILITY

For the perfect fit, you have a choice of two front loader sizes for each 6M model.

	603R	623R	643R	663R	683R
6090M, 6100M, 6110M, 6120M	■	■	-	-	-
6130M, 6140M	-	■	■	-	-
6145M, 6155M	-	-	■	■	-
6175M, 6195M	-	-	-	■	■



OPTIONAL R LOADER FEATURES

We have a range of optional solutions that help you access all the built-in benefits of your John Deere R Series front loader. They'll save you time, boost convenience and reduce operator fatigue.



EASY BUCKET UNLATCH

Nothing beats the convenience of hydraulic bucket unlatch with the cab mounted switch – all in a straightforward combination gas accumulator/oil pressure system.



LOADER LIGHTS

Purpose-built John Deere loader lights provide the consistent and reliable illumination you need when working with a front loader in darkness or poor visibility. Our lights fit perfectly and also offer exceptional value.



LOADER SUSPENSION

Activated from the joystick, its effective damping provides a smoother ride for load, tractor and operator.













From simple pallet forks to multi bale grapples, John Deere offers numerous attachments.

WHICH LOADER?

Based on your application, let's narrow down which model is going to work best for you.

The versatile and affordable M loaders are ideal for all standard front loader tasks such as collecting bales, feeding cattle and moving pallets.

If you need extra lift capacity, perform heavy-duty operations such as forestry and earthwork, or if you're looking for even better visibility, enhanced comfort and performance, our R Series loader will be best for you.

	M LOADER	R LOADER
 Lift capacity		
 Collect bales	✓	✓
 Feed cattle	✓	✓
 Move pallets	✓	✓
 Digging/heavy duty		
 Suspension	□	✓
 Lights	-	□

✓ base □ optional - not available

MAKE THE MOST OF YOUR DAY

AUTOTRAC

AutoTrac hands-free steering adds more comfort: It reliably steers your tractor from day to night, through dust or on hilly terrain. That prevents costly overlaps or gaps and enables every operator to work at peak performance.

FIND YOUR AUTOTRAC SOLUTION

Choose between AutoTrac on the Corner Post Display or AutoTrac Complete. AutoTrac on the Corner Post Display conveniently integrates AutoTrac into the in-base Corner Post Display of your 6M, comes with a StarFire 6000 Receiver and includes a lifetime activation from the factory.

AutoTrac Complete also gets you the Gen4 4240 Universal Display, a StarFire 6000 Receiver and an AutoTrac activation – the full ready-to-go package.

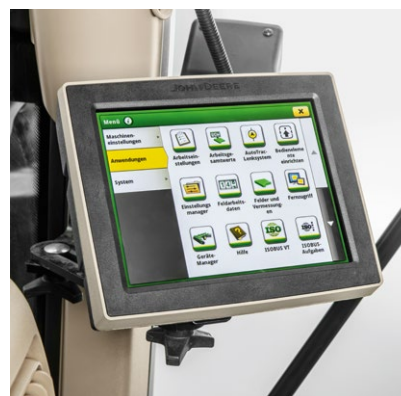

The 4240 Universal Display enables AutoTrac Complete and adds advanced automation features like section control and documentation to your 6M.

AutoTrac on the Corner Post Display leverages your in-cab display in the A-post for AutoTrac.



8%*
INPUT SAVINGS

14%**
PRODUCTIVITY
INCREASE

THE STARFIRE 6000 RECEIVER

Fascinating with yet a new level of accuracy, signal stability and repeatability

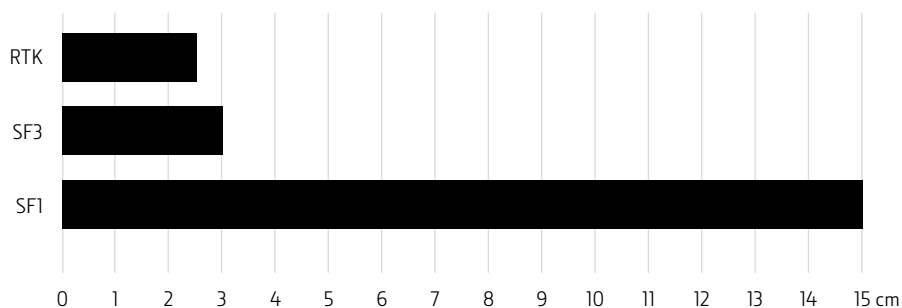

- RTK with 2.5 cm: Pass-to-pass accuracy, featuring long-term repeatability including 14 days RTK Extend if you lose line of sight or mobile network.
- SF3 enabling 3 cm: Pass-to-pass accuracy and 9-month in-season-repeatability.
- Improved SF1 with 15 cm: Pass-to-pass accuracy, free of charge.

The John Deere Mobile RTK Signal can be operated via JDLink***. Saving you the extra cost for an RTK Modem and the annual cost for a SIM-card with data plan. (Check country availability).

* From 'Lohnunternehmen' 1/2010

** From 'Landtechnik' 6/2006

*** Requires a JDLink telematics module and an active JDLink subscription

AUTOTRAC. NOW CONNECTED.

Together, AutoTrac and the John Deere Operations Center connect your office and your machines to improve overall business efficiency.

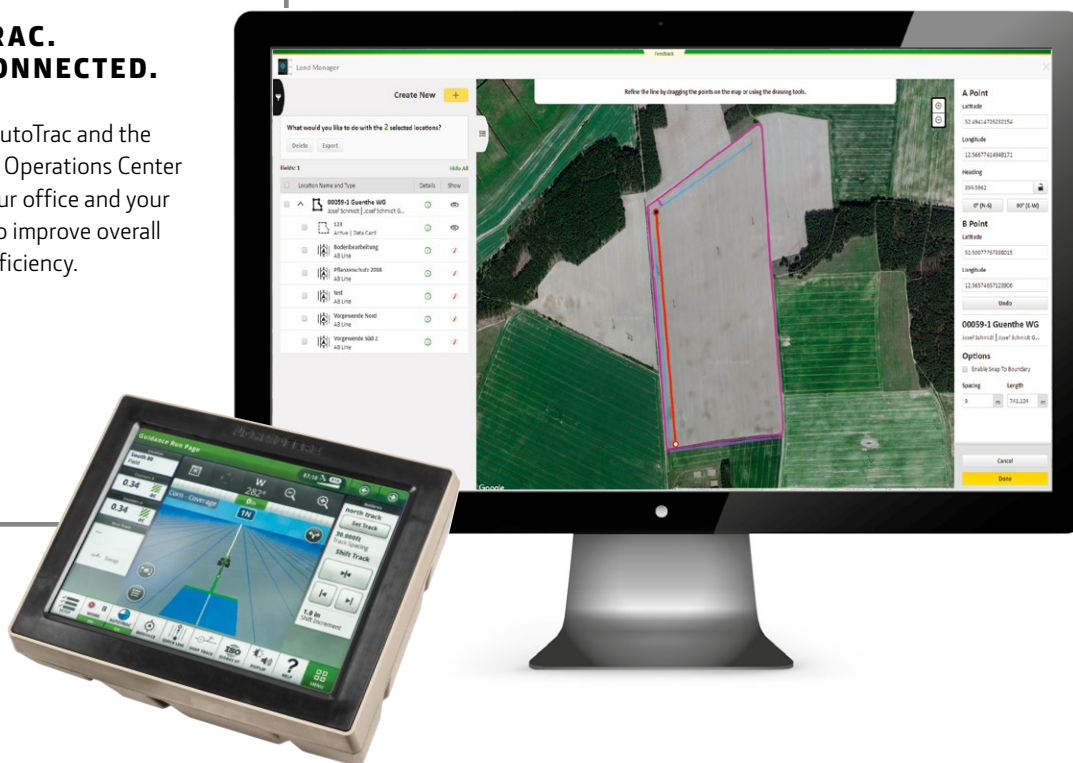

CONNECT TO REDUCE IN-FIELD SET-UP TIME

AUTOTRAC ONLINE

+ YOUR BENEFIT

- Quick and easy in-field display set-up
- Automated, reliable and error-free documentation
- Automated data back-up

Connect AutoTrac to the John Deere Operations Center and you can carefully plan your jobs during off-season. Easily create, edit or delete display set-up data like clients, farms and fields, boundaries, guidance lines and much more. All you need to wirelessly exchange data between your tractor and the Operations Center is a JDLink modem and a JDLink connect subscription.

New field boundaries can be easily imported from a subsidy application portal or farm management software via shapefile. You can also draw them online or modify any existing boundaries, which is a great help for first time field localisation, especially if you contract or use seasonal employees. When you're done you can wirelessly send all data to the machines you select at the push of a button – eliminating time-consuming and error-prone manual set-up on multiple displays in the field. When you approach a new field, the related client, farm and field data will automatically be detected. Upon confirmation, the boundaries are loaded, and the preferred guidance line can be chosen from a pre-populated list. Finally, your display data is always backed up.

DOCUMENTATION MADE EASY

MANAGE YOUR FIELDS THE SMART WAY

The John Deere Operations Center puts your farm in your pocket: Easy to understand, integrated tools support your agronomic decision making and help you get maximum yield and consistent quality from your soil at significantly reduced input costs. Plan your crop rotation and tasks for the upcoming season with a structured overview that will make it effortless to create display set-up files and work orders. As the individual tasks are being completed, your documentation data is automatically uploaded from your in-cab display to your personal Operations Center account. From there all operational details are easily visualised on a nicely structured timeline – anytime, anywhere, from any internet-capable device, allowing you to view your mapping or compare different map layers like yield, dry matter, crop constituents and application rates.

This is how you turn valuable agronomic insights into smart decisions and more easily define corrective actions. Other integrated tools enable you to easily turn this data into site-specific variable rate prescriptions and allow you to collaborate with agronomic advisors by granting them field-specific access rights. Finally, documenting your work for clients becomes simple with easily created, printed and shared reports.

+ YOUR BENEFIT

- All info in one centralised location, nicely structured and easily accessible
- Gain insights for smart, fact-based decisions
- Leverage numerous additional agronomic tools for further data processing and analysis
- Easy and fast data transfer with Wireless Data Transfer

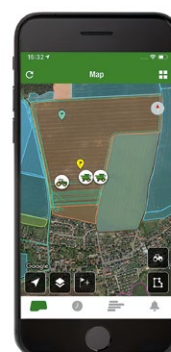

NEW: MYOPERATIONS APP

All the insight you need for fact-based decision making – conveniently displayed on your smartphone.



SERVICES THAT BENEFIT YOU

FARMSIGHT SERVICES

John Deere dealers have access to several cutting-edge digital remote tools that allow them to provide you with a suite of proactive services tailored to your needs. 6M tractors can be ordered with a JDLink telematics module, including a free 5-year subscription. To start benefiting from that, you simply need to provide your consent and agree with your John Deere dealer on the scope of your FarmSight Services package.

FARMSIGHT SERVICES PACKAGES

	IN BASE	SELECT	PREMIUM	ULTIMATE
1 Pre-Delivery Inspection	■	■	■	■
2 MyJohnDeere Account Setup	■	■	■	■
3 Machine Handover Training	■	■	■	■
4 Remote Machine Monitoring (incl. Expert Alerts)	■	■	■	■
5 Automatic Maintenance Planning	■	■	■	■
6 Operations Center Introduction	-	■	■	■
7 Seasonal Phone Support	-	■	■	■
8 Expert Check	-	■	■	■
9 Optimisation Visit	-	-	■	■
10 Remote Operator Support	-	-	■	■
11 Remote Performance Check	-	-	■	■
12 Back-up machine	-	-	-	■

* The FarmSight Services packages content and prices are defined by your local John Deere dealer and can deviate in scope and composition.

EXPERT ALERTS

Expert Alerts, our newest remote diagnostics advancement, is based on smart software algorithms that can predict many potential technical issues before they have a negative impact or cause damage. Repairs become plannable while downtime and costs can be reduced significantly.

REMOTE MACHINE MONITORING

It's yet another service that sets John Deere apart. On your consent, our Machine Dashboard displays the operating condition data and error codes to your dealer in real time. He can remotely connect to the machine, run further diagnostics and perform remote software updates to help you faster than ever before. Plus, our new Expert Alerts are included as well.

AUTOMATIC MAINTENANCE PLANNING

You'll always be perfectly on track with your maintenance. Automated notifications can be based on actual machine hours or calendar dates and alert you to maintenance tasks which need to be performed.

MYJOHNDEERE ACCOUNT SETUP

This service includes the basic set-up of a MyJohnDeere account and Operations Center organisation to connect your machine.

REMOTE OPERATOR SUPPORT

You need instant advice and can't wait for someone to come to the field? Remote Display Access allows your dealer expert to remotely assist you and your operators with machine/ implement setup and more – like being virtually in the cab.

EXPERT CHECK

Using a special John Deere inspection checklist, your dealer expert performs a thorough technical examination of your machine. He will advise you on what measures to take and take care of all relevant software updates to ensure maximum uptime in the next season.

OPERATIONS CENTER INTRODUCTION

You want to properly store and manage field boundaries, guidance lines, documentation data and have access to a full suite of farm management tools? Then this is the right package element for you.

OPTIMISATION VISIT

Benefit from dealer product specialist experience to fully exploit your machine's capabilities. Thanks to their detailed product knowledge, dealer product specialists can help you by reviewing your current machine settings and providing improvement recommendations.



POWERGARD™

STATUS: PROTECTED

When you protect your equipment with a PowerGard™ maintenance plan, your business has the steady machine uptime and non-stop peak performance it needs to thrive.





PowerGard™ agreements protect you against unexpected repair costs and keep your maintenance on track with genuine parts. Three fixed rate packages provide increasingly comprehensive levels of cover to keep your machine running at peak performance with steady uptime.

POWERGARD™ MAINTENANCE

Preventative maintenance work – it's essential for keeping equipment in good working order based on factory recommended intervals.*

POWERGARD™ PROTECTION

Base level of protection that covers unusual events that can lead to costly repairs, and also covers the main drive train components.

POWERGARD™ PROTECTION PLUS

The ultimate in protection – the total peace of mind package that covers all components included in PowerGard™ Protection, plus electrical, cooling, hydraulics and more.

FINANCING

Include your PowerGard™ Protection agreements into your financing offer and benefit from competitive rates, with flexible payments.*

* PowerGard™ agreements and Financing for PowerGard™ Maintenance is currently only available with participating dealers. Country regulations apply.

YOUR WORKPLACE, YOUR CHOICE

It's where you work, so make it yours by choosing our Select, Select+ or Premium editions.

SELECT

Our popular Righthand Console, a PowrQuad or AutoQuad transmission, an Economy Seat and mechanical SCV's.



SELECT+

A convenient AutoQuad Plus, CommandQuad Plus or comfortable AutoPowr transmission, standard seat and mechanical or electronic SCV's.



PREMIUM

The acclaimed compact CommandARM, a CommandQuad or AutoPowr transmission, the Premium Seat and electronic SCV's, and many other comfort and performance features.





EDITIONS

	SELECT	SELECT+	PREMIUM
	Powr/AutoQuad, RH Console, mSCV's	AutoQuad/ CommandQuad/ AutoPowr, RH Console, e-mSCV, TLS	CommandQuad/ AutoPowr, CommandARM, eSCV's, TLS and Cab Suspension
TRANSMISSION			
PowrQuad	■	–	–
AutoQuad	□	■	–
CommandQuad	–	□	■
AutoPowr	–	□	□
CHASSIS			
TLS w or w/o brakes	□	■	■
Hitch lift capacity and payload upgrade (6090M-6140M)	□	■	■
CAB			
Cab suspension	–	□	■
Compact CommandARM	–	–	■
Economy seat (mech)	■	–	–
Standard seat (air)	□	■	–
Premium Seat (air)	–	□	■
Select Light package	■	–	–
Select+ Light Package	□	■	–
Premium Light Package	–	□	■
iTEC basic	□	□	■
Radio prep (includes DAB antenna)	■	–	–
Standard Radio (includes DAB antenna but no DAB function)	□	■	■
Addtl. storage compartment LH side	■	■	■
Cooling compartment	–	□	□
Front and rear roller blind	□	□	■
ISOBUS Ready or AutoTrac Ready	□	□	■
HYDRAULICS			
Hydraulic pump 80 l/min (PC)	■ (6090M-6140M)	–	–
Hydraulic pump 114 l/min (PFC)	□ (6090M-6140M) ■ (6145M-6155M)	■	■
Hydraulic pump 155 l/min (PFC)	–	□ (6175M-6195M)	■ (6175M-6195M)
Mechanical SCV's (200 Series)	■	–	–
Mechanical SCV's (450 Series)	□	■	–
Electrical SCV's	–	□	■
PTO Remote Control	–	□	■
Lift link adjustment LH & RH	■	■	■

Legend: ■ base for editions; □ optional for editions; – excluded for editions

SPECIFICATIONS

	6090M	6100M	6110M	6120M
ENGINE PERFORMANCE				
Rated power (ECE-R120), hp (kW)	90 (66)	100 (74)	110 (81)	120 (88)
Rated power with IPM (ECE-R120) @ 2,100 rpm, hp (kW)	110 (81)	120 (88)	130 (96)	140 (103)
MAX. POWER (ECE-R120), HP (KW)	100 (73)	111 (81)	122 (90)	133 (98)
MAX. POWER WITH IPM (ECE-R120), HP (KW)	114 (84)	125 (92)	135 (99)	145 (107)
Constant power range, rpm	2,100-1,500	2,100-1,500	2,100-1,500	2,100-1,500
Torque reserve, % percentage	40			
Maximum torque, Nm (at 1,600 engine rpm) – without boost	421	468	515	562
Rated speed, rpm	2,100			
Manufacturer	John Deere Power Systems			
Type	PowerTech EWL			
Aftertreatment	Diesel Oxidation Catalyst (DOC) and Selective Catalytic Reduction (SCR) using DEF			
Engine air filter	PowerCore® G2 air filter with pre-cleaning			
Aspiration	Single turbocharger with wastegate			
Cylinders / Displacement	4 / 4.5 l			
Cooling system	Stacked ducted system with mechanical (bi-metal) visco clutch			
Fuel injection system & control	High pressure common rail system HP3-Denso			
TRANSMISSIONS				
POWRQUAD PLUS				
16 / 16.3.2 - 38 km/h	■	■	■	■
20 / 20.2.5 - 40 km/h	-	-	-	-
24 / 24.1.4 - 40 km/h	■	■	■	■
AUTOQUAD PLUS				
20 / 20.2.5 - 40 km/h	-	-	-	-
24 / 24.1.4 - 40 km/h	■	■	■	■
AUTOQUAD PLUS ECOSHIFT				
20 / 20.2.5 - 40 km/h	-	-	-	-
24 / 24.1.4 - 40 km/h	■	■	■	■
COMMANDQUAD PLUS				
20 / 20.2.5 - 40 km/h	-	-	-	-
24 / 24.1.4 - 40 km/h	■	■	■	■
COMMANDQUAD PLUS ECOSHIFT				
20 / 20.2.5 - 40 km/h	-	-	-	-
24 / 24.1.4 - 40 km/h	■	■	■	■
Creeper (PowrQuad Plus, AutoQuad Plus and AutoQuad Plus EcoShift)	■	■	■	■
AUTOPOWR				
0.05 - 40 km/h	■	■	■	■
AXLES				
Suspended front axle (option)	Triple Link Suspension (TLS) MFWD Axle, hydro-pneumatic, permanently active, triple link, self-levelling suspension			
Suspension range with TLS Plus	100 mm suspension range			
Engagement front differential lock	Self-locking differential			
Engagement rear differential lock	Electro-hydraulic with oil cooled clutch			
Rear axle	Flange axle/ Rack and Pinion axle			
STEERING				
Type	Dynamic load sensing, hydrostatic, flow metering			
HYDRAULIC SYSTEM				
Type	Pressure Compensated (PC) / Pressure & Flow Compensated (PFC) system with load sensing function			
Flow at rated engine speed base / option, l/min	80 / 114			
Selective control valves	Up to 4 rear + 3mid			
Power Beyond	Optional			
Oil take out capacity with overfill, l	25			
Oil take out capacity with overfill with additional oil reservoir, l	No overfill			

6130M	6140M	6145M	6155M	6175M	6195M
130 (96)	140 (103)	145 (107)	155 (114)	175 (129)	195 (143)
150 (110)	160 (118)	n/a	n/a	n/a	n/a
144 (106)	155 (114)	161 (118)	172 (126)	194 (143)	216 (159)
156 (115)	166 (122)	-	-	-	-
2,100-1,500	2,100-1,500	2,100-1,500	2,100-1,500	2,100-1,500	2,100-1,500
40					
609	656	680	726	820	914
2,100					
John Deere Power Systems					
PowerTech PSS			PowerTech PVS		
Lifetime Diesel Particle Filter (DPF), Diesel Oxidation Catalyst (DOC) and Selective Catalytic Reduction (SCR) using DEF					
PowerCore® G2 air filter with pre-cleaning					
Dual turbochargers, variable geometry turbo with fixed geometry turbo in series			Variable geometry turbo charger		
4 / 4.5 l			6 / 6.8 l		
Stacked ducted cooling system with visco clutch					
High pressure common rail system, electronically controlled			High pressure common rail system, electronically controlled		

■	-	-	■	■	■
-	-	-	■	■	■
■	■	■			
-	-	-	■	■	■
■	■	■	-	-	-
-	-	-	■	■	■
■	■	■	-	-	-
-	-	-	■	■	■
■	■	■	-	-	-
-	-	-	■	■	■
■	■	■	■	-	-
■	■	■	■	-	-
■	■	-	-	-	-

Triple Link Suspension (TLS) MFWD Axle, hydro-pneumatic, permanently active, triple link, self-levelling suspension					
100 mm suspension range					
Self-locking differential					
Electro-hydraulic with oil cooled clutch					
Flange axle/ Rack and Pinion axle					

Dynamic load sensing, hydrostatic, flow metering					
--	--	--	--	--	--

Pressure Compensated (PC) / Pressure & Flow Compensated (PFC) system with load sensing function		Pressure & Flow Compensated (PFC) system with load sensing function			
80 / 114		114		114 / 155	
Up to 4 rear + 3mid					
Optional					
20		37		25	
32		37		42	

SPECIFICATIONS

	6090M	6100M	6110M	6120M
3-POINT HITCH – REAR				
Type	Electronic lower link sensing; load & depth control, infinite mix, float			
Category	II/IIIN			
Maximum lift capacity at hooks, kg (base/option)	4,350 / 5,700			
Lift capacity through full lift range (OECD 610 mm), kg (base/option)	2,750 / 3,600			
3-POINT HITCH – FRONT, OPTIONAL				
Type	Front hitch controlled by 1st rear SCV			
Category	IIIN			
Maximum lift capacity at hooks, kg	4,000			
Lift capacity through full lift range (OECD at the hooks), kg	3,300			
REAR PTO				
Type	Electro-hydraulically engaged, oil cooled, multi-disc design			
Engine rpm at rated PTO speeds with 540 option	1,948			
Engine rpm at rated PTO speeds with 540/1,000 option	1,977 / 1,972			
Engine rpm at rated PTO speeds with 540/540E/1,000 option	1,977 / 1,503 / 1,972			
FRONT PTO, OPTIONAL				
Type	Electro-hydraulically engaged, oil cooled, multi-disc design			
Engine speed at rated PTO speed (1,000), rpm	1,969			
CAB				
Specifications	310° all-round vision cab with 2 B-post doors, telescoping and tiltable steering column / wheel			
Suspension (option)	Mechanical cab suspension (MCS)			
Noise level at operator's ear, dB(A)	70			
Cab glass area, m ²	4.85			
Display	Corner post display located at A-post			
MISCELLANEOUS				
AutoTrac Ready	Optional			
ISOBUS ready	Optional			
ISOBUS implement connection	Optional			
Immobiliser	Optional			
Trailer brake systems (options)	Hydraulic and / or pneumatic system			
Pneumatic trailer brake system (option)	2 line system, park brake actuation engages trailer brakes, comes with air dryer			
CAPACITIES				
Fuel Tank (base/option), l	175 / 205			
DEF tank, l	19			
Engine coolant, l	20			
DIMENSIONS AND WEIGHTS				
Wheelbase, mm	2,400			
Width x Height x Length, mm (maximum)	2,440 x 2,850 / 2,900* x 4,327 [600 / 65R38 (175)]			
Width x Height x Length, mm (minimum)	2,250 x 2,715 / 2,763* x 4,327 [420 / 85R30 (148)]			
<i>Measured with flanged axle, up to cab roof, from front hydraulic to horizontal draft link hooks and with min. / max. front tyres, min. / max. rear tyre sizes.</i>				
Ground clearance, mm (min. / max.)	364 / 500			
<i>Measured at centre of front axle, using max. front and max. rear tyre sizes.</i>				
Shipping weight, kg	5,750			
<i>Measured with average specifications.</i>				
Maximum permissible gross weight, kg	10,450			
TYRE SIZES				
Front tyre sizes, max. available (diameter in cm)	540 / 65R24 (134)			
Rear tyre sizes, max. available (diameter in cm)	600 / 65R38 (175)			

* without cab suspension/ with cab suspension

6130M	6140M	6145M	6155M	6175M	6195M
Electronic lower link sensing; load & depth control, infinite mix, float					
II/IIIN	IIIN			IIIN/III	
5,700 / 6,400	6,400	7,650		9,050	
3,600 / 4,100	4,100	3,950		5,150	
Front hitch controlled by 1st rear SCV					
IIIN					
4,000					
3,300					
Electro-hydraulically engaged, oil cooled, multi-disc design					
n/a					
1,977 / 1,972		1,997 / 2,010		1,960 / 1,960	
1,977 / 1,503 / 1,972		1,997 / 1,762 / 2,010		1,960 / 1,729 / 1,960	
Electro-hydraulically engaged, oil cooled, multi-disc design					
1,969					
310° all-round vision cab with 2 B-post doors, telescoping and tiltable steering column / wheel					
Mechanical cab suspension (MCS)					
70					
4.85					
Corner post display located at A-post					
Optional					
Optional					
Optional					
Optional					
Hydraulic and / or pneumatic system					
2 line system, park brake actuation engages trailer brakes, comes with air dryer					
225 / 195	265	270		325	
13		16		20	
22		27		28	
2,580		2,765		2,800	
2,490 x 2,940 x 4,485	2,490 x 2,990 x 4,730	2,490 x 3,030 x 4,730		2,550 x 3,185 x 4,990	
-	-	-	-	-	-
490		530		545	
5,800	6,200	6,700		7,500	
10,450		11,000		12,300	
540 / 65R24 (134)	540 / 65R28 (144)	600 / 65R28 (152)			
600 / 65R38 (175)	650 / 65R38 (185)	710 / 70R38 (200)			

LOADER SPECIFICATIONS



The American Society of Agricultural and Biological Engineers is an educational and scientific organization dedicated to the advancement of engineering applicable to agricultural, food, and biological systems. Founded in 1907 and headquartered in St. Joseph, Michigan, ASABE comprises 8,000 members in more than 100 countries.

SHORT FRAME 6M				6090/ 6100/ 6110/ 6120M	
LOADER MODEL				603M	
LEVELLING SYSTEM				MSL	
Front tyre				540/65R24	
Rear tyre				600/65R38	
LOADER					
Bucket				1,850 Standard	
Bucket Weight				lb / kg	475 216
Lift capacity @ full height	Measured @ 800 mm ahead of pivot	(V)	lb / kg	3,754	1,703
Maximum lift height		(A)	in / mm	155	3,937
Reach	@ Maximum height	(D)	in / mm	32	813
Cycle times	Loader raise		sec	4	

SMALL FRAME 6M				6130/ 6140M	
LOADER MODEL				623M	
LEVELLING SYSTEM				MSL	
Front tyre				540/65R24	
Rear tyre				600/65R38	
LOADER					
Bucket				2,200 Standard	
Bucket Weight				lb / kg	538 244
Lift capacity @ full height	Measured @ 800 mm ahead of pivot	(V)	lb / kg	3,891	1,765
Maximum lift height		(A)	in / mm	162	4,120
Reach	@ Maximum height	(D)	in / mm	30	752
Cycle times	Loader raise		sec	6.6	

MID FRAME 6M			
LOADER MODEL			
LEVELLING SYSTEM			
Front tyre			
Rear tyre			
LOADER			
Bucket			
Bucket Weight			
Lift capacity @ full height	Measured @ 800 mm ahead of pivot	(V)	lb / kg
Maximum lift height		(A)	in / mm
Reach	@ Maximum height	(D)	in / mm
Cycle times	Loader raise		sec

LARGE FRAME 6M			
LOADER MODEL			
LEVELLING SYSTEM			
Front tyre			
Rear tyre			
LOADER			
Bucket			
Bucket Weight			
Lift capacity @ full height	Measured @ 800 mm ahead of pivot	(V)	lb / kg
Maximum lift height		(A)	in / mm
Reach	@ Maximum height	(D)	in / mm
Cycle times	Loader raise		sec

The values may vary according to the tractor and loader settings/configuration.

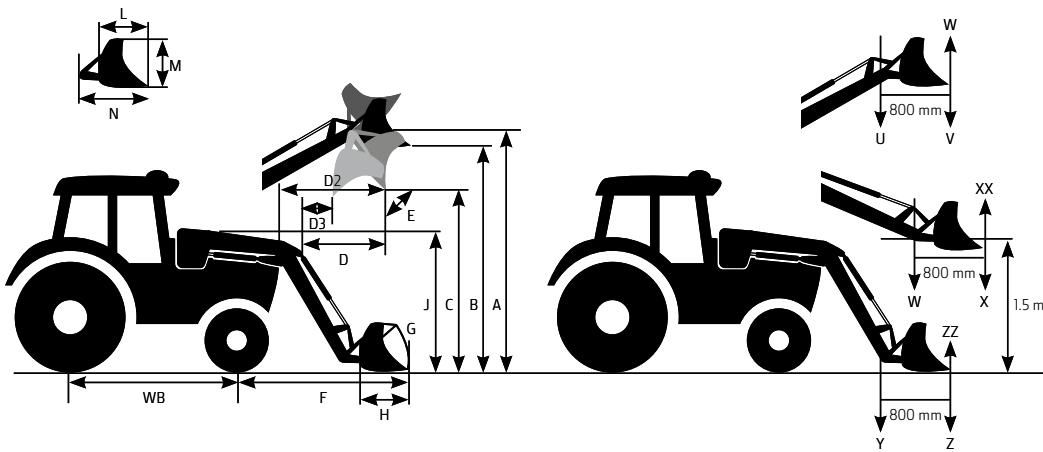

6090/ 6100/ 6110/ 6120M

623M		603R				623R			
MSL		NSL		MSL		NSL		MSL	
540/65R24				480/70R24					
600/65R38				520/70R38					
2,200 Standard		1,850 Standard				2,200 Heavy Duty			
538	244	520	236	520	236	683	310	683	310
3,902	1,770	3,363	1,524	4,350	1,971	3,826	1,734	4,749	2,152
162	4,121	153	3,899	153	3,900	160	4,090	160	4,090
30	751	37	944	37	944	32	831	32	831
6.6		3.1		4.1		3.4		3.4	

6130/ 6140M

643M		623R				643R			
MSL		NSL		MSL		NSL		MSL	
540/65R24				480/70R24					
600/65R38				520/70R38					
2,200 Standard		1,850 Standard				2,200 Heavy Duty			
538	244	520	236	520	236	683	310	683	310
4,228	1,918	3,874	1,757	5,009	2,272	3,902	1,770	5,137	2,330
164	4,159	162	4,124	162	4,124	163	4,151	163	4,151
36	920	30	759	30	759	39	982	39	982
4.5		3.4		3.4		3.5		3.3	

6145/ 6155M

643M		643R				663R			
MSL		NSL		MSL		NSL		MSL	
480/70R28				480/70R28				540/65R28	
580/70R38				580/70R38				650/65R38	
2,200 Standard		Heavy Duty 2,150 mm				Heavy Duty 2,450 mm			
538	244	683	310	683	310	783	355	783	355
4,134	1,875	4,006	1,817	5,024	2,279	4,065	1,844	5,130	2,327
169	4,300	169	4,300	169	4,300	177	4,495	177	4,495
25	638	33	841	33	841	40	1,026	40	1,026
4.7		3.7		3.5		4.0		3.9	

6175/ 6195M

663R		683R			
NSL		MSL		MSL	
		600/65R28			
		710/70R38			
		2,450 Heavy Duty			
783	356	783	356	783	356
4,094	1,857	5,185	2,352	5,525	2,506
178	4,520	178	4,520	176	4,480
40	1,004	40	1,004	53	1,335
4.0		3.9		4.2	

NEED MORE DETAILS?
 Visit the Front Loader section of the John Deere website.

NOTHING RUNS LIKE A DEERE™

Chances are that when you need us, you need us right away. For advice, to solve a problem, or for a part. Reach out, we'll be there with technicians who are factory trained, ready to go to work for you, using only genuine John Deere parts and products. Our commitment to quality doesn't stop at your machine – we also have finance options available that are guaranteed to fit your budget and your plans.



This literature has been compiled for worldwide circulation. While general information, pictures and descriptions are provided, some illustrations and text may include finance, credit, insurance, product options and accessories not available in all regions. Please contact your local dealer for details. John Deere reserves the right to change specification and design of products described in this literature without notice. The green and yellow colour scheme, the leaping deer logo and the JOHN DEERE word mark are trademarks of Deere & Company.